

DOI: 10.19275/RSEP060

Received: 14.02.2019

Accepted: 08.05.2019

AN EMPIRICAL STUDY ON THE IMPACT OF RISK PERCEPTION ON GERMAN CONSUMERS' ONLINE BUYING INTENTION

Farzaneh Soleimani Zoghi

PhD, SRH University of Applied Sciences Berlin
far.soleimani@gmail.com

Abstract

An online purchase decision confronts consumers with some challenges. Internet offers consumers access to a vast amount of information but the sources of information mostly are not reliable. Literature suggests that perception of risk acts as barrier to online shopping. The aim of this study is to determine the impact of perception of risk on consumers' online buying intention in Germany. Moreover, in order to get indications of consumers' online shopping behavior, the effect of perceived behavioral control and e-WOM credibility has also been investigated. In this research different analysis including descriptive statistics, confirmatory factor analysis and multiple regression analysis have been used. The *hypotheses* of the research have been *partially supported*. *The results indicate that perceived behavioral control has influence on consumers' perception of risk and online buying intention*. However, e-Wom credibility didn't have any effect on *consumers' perception of risk* and online buying intention. Moreover findings of current study do not support any significant relationship between *consumers' perception of risk and their online buying intention in Germany*.

Keywords: Online Buying Intention, Perceived Behavioral Control, e-WOM Credibility, Perception of Risk

JEL Classification: M13, M20, M31

Citation: Zoghi, F.S. (2019) An Empirical Study on the Impact of Risk Perception on German Consumer's Online Buying Intention, Review of Socio-Economic Perspectives, Vol 4(1), pp. 1-14, 10.19275/RSEP060

1. Introduction

Through the internet, business could easily reach out the consumers and stay in contact with them. In a recent research, one of the world's leading market intelligence agencies, called Mintel, has revealed that on 2017, 93 percent of Germans have shopped online by using computer, laptop, tablet and smartphone. Choice availability and ease of comparing different products is among the top of priorities to online shopping in Germany (Mintel, 2017). Shared databases, document repositories, workflow applications and discussion forums make the accessibility to knowledge for organizations easier (Lopez-Nicolas and Molina-Castillo, 2008: 103). On the other hand, the interactive elements of electronic platforms such as social media platforms have shifted the power from companies toward the consumers and have changed customer relationship management drastically. Therefore, e-Wom and user generated sources of information have provided more help for consumers to control their media behavior. In consumer behavior literature, risk perception has been acknowledged as critical factor in buying decision-making process and has a restrainer function in purchase behavior (Peter and Ryan, 1976). Lutz and Reilly (1974) have suggested that e-Wom is a crucial factor for reducing risk perception in online purchase process. Perceived behavioral control which has been defined as individual's perception regarding to the ease or difficulty of performing a given behavior (Ajzen, 1991), has been examined as the second key factor that reduce risk perception and positively affects online purchase intention. This study aim to expand the knowledge of consumers' purchase behavior on online platforms by examining the impact of e-WOM Credibility, perceived behavioral control and risk perception on consumers' online buying intention in Germany.

2. Theoretical Background

2.1. Purchase Intention vs Purchase Performance

According to the theory of planned behavior, "performance of a behavior is a joint function of intentions and perceived behavioral control" (Ajzen, 1991). One of the key factors in the theory of planned behavior is Intention to perform a given behavior. Intentions are influenced by motivational factors (Ajzen, 1991). However, some non-motivational factors such as money, time, skills and cooperation of other people (Ajzen, 1985) should also be available. It has been assumed that the stronger the intention to perform a behavior, the more likely is the behavior. In other words motivations increase the intention of performing a behavior and access to required resources increase the probability of succeeding in the performance.

Researches propose that the intention to perform a behavior is the most related cognitive antecedent for the actual performance of the behavior (Fishbein & Ajzen, 1975). In another word, we should be able to predict a specific behavior based on individual's intention to engage in the behavior. However the time interval between measuring intended behavior and assessing actual behavior should be taken to consideration because with the passage of time changes in external factors, such as events, may affect intentions and cause them to change. So large time interval between measurement of intention and assessment of the behavior will make the intention a poor predictor of expected behavior (Ajzen and Fishbein, 2005).

Even when the measures of intention and behavior are stable and compatible, a gap between words and deeds must be taken into consideration. Donald campbell (1963) suggests that the illogical lack of compatibility between what people say and do is

because some intentions are difficult to be performed as a behavior. A recent study (Ajzen, Brown, & Carvajal, 2004) shows that participants agree to contribute money to a scholarship fund when the question was hypothetical however under real payment situation many of them chose not to make any contribution.

2.2. Key Factors of Online Purchase Experience

Literature on consumer behavior suggests different approaches toward successful performance outcomes in online purchase platforms. The importance of customer experience on the growth of e-retailing has been recognized by Elliot and Fowell (2000). Motwani (2016) has emphasized on the importance of consumer's attitude, intent and behavior to achieve competitive advantage in online platforms. Gentile, Spiller, and Noci (2007) has found evidence of six key components of online customer experience which includes sensorial, emotional, cognitive, pragmatic, lifestyle, and relational components. Rose and et al. (2012) have developed a model of the relationship between antecedents and outcomes of online customer experience. They have empirically tested their model on 220 online shoppers in USA and Europe. Their findings suggest that factors such as skill, technical capability of the users and speed of the website are not any more determinants of judgment of online purchase experience, rather technical functionality of e-retail websites including visual design and graphical features is important. One more important finding in this research emphasis on a sense of control by consumers which influence their feelings in online transactions. According to the research source of control is consist of three factors; the ease of use, ability to customize one's own space and connectedness (Rose and et al., 2012).

2.3. Perceived Behavioral Control in Online Buying

Many investigations have shown that individual's behavior is strongly influenced by their confidence in their ability to perform a task; Ajzen (1991) in the theory of planned behavior has defined Perceived behavioral control as individual's perception regarding to the ease or difficulty of performing a given behavior. Atkinson (1964) in theory of achievement motivation has quite similar view and defined expectancy of success as the perceived probability of succeeding at a given task. Bandura (1982) has defined perceived self-efficacy as the judgments of how well an individual can execute courses of action to deal with a prospective situation.

Dutta et al. (2015) have defined personal innovativeness as the degree of willingness of an individual to try out any new domain-specific information technology or innovation (Dutta et al., 2015: 532). Personal innovativeness can be defined at either global trait level, or domain-specific level. Domain specific innovativeness is defined by the virtue of identifiable characteristics and actual acquisition of new information, ideas and products (Lin and Fillieri, 2015: 159). Agarwal and Prasad (1998) have found out that personal innovativeness is strictly correlated with technology awareness, technology adoption and technology acceptance. When technology becomes critical, these issues' importance rises (Agarwal and Prasad, 1998: 204). A recent study on online purchase intention on Turkish customers has shown that personal innovativeness increase online shopping intention and reduces the perception of online purchase risk (Bilgen and S. Zoghi, 2017)

Davis (1989) in Technology Acceptance Model has proposed perceived usefulness and perceived ease of use as two factors that affect individual's intention to use technology. According to the model perceived usefulness is the extent to which an individual believes that the use of technology will improve one's job performance. Perceived ease of use is the extent to which an individual perceives the usage of the technology easy and effortless.

Innovation diffusion theory views the diffusion as the process by which the innovation flows from one person to another through the social system. Five attributes of innovation have been indicated as influential in adoption process which includes relative advantage of using the innovation compare to the prior practice, compatibility of the innovation with what people do, complexity of usage, observability of the results to others and trialability before adopting or rejecting the innovation (Rogers, 2003). Innovation characteristics such as relative advantage, complexity of usage, result demonstrability and image are among most important factors in predicting user intention to use an innovation (Yi, et al, 2006). Many scholars have developed specific scales to measure innovativeness in distinct products and services based on innovation diffusion theory (Jackson, Yi and Park, 2013: 154). Hence;

H₁: Perceived behavioral control has a significant effect on perception of risk.

H₂: Perceived behavioral control has a significant effect on online buying intention.

2.4. e-WOM Source Credibility

e-Wom has been defined as "any positive or negative statement made by potential, actual, or former customers about a product or company, which is made available to a multitude of people and institutions via the internet" (Hennig-Thurau et al, 2004). Digital communication platforms have helped individuals and marketers to share information easily and to spread electronic word of mouth (e-WOM). There are many pros and cons regarding to e-Wom impact; e-WOM positive impact includes the dimensions below (Levy and Gvili, 2015: 96):

- Because of digital channels, business and target market have more strong relationship.
- E-Wom facilitates the flow of more specific and detailed information among consumers.
- Most forums employ people to manage the communication activity.

However, source credibility is one of the major construct within e-Wom that might have negative impact. Do people trust on the message sources and find it credible? For a message to be considered credible the source has to be trustworthy and it must possess appropriate level of expertise and knowledge of the subject to make a specific judgment about the product or service (Kelley et al., 2016). Recent studies have showed that online reviews may increase or decrease customer satisfaction. Objective reviews tend to affect intentions. Moreover, consumers are able to easily understand these reviews and it is an advantage for these reviews (Obiedat, 2013: 17). Some of other independent factors which influence credibility are valence, objectivity, subjectivity, volume, usefulness and being attribute-centric (Lee and Koo, 2012: 1981). Kelley et al. (2016) have proposed that because of unique characteristics of the online environment additional factors that the authors refer to as message relevance affect the impact of eWOM communication on consumer decision making. The authors have identified two dimensions underlying

message relevance; the first dimension is “persona similarity” which refers to the degree that a consumer who posts information online is like the person that read the information in terms of character, background, and expectations and the second dimension is “usage similarity” which refer to the degree which a consumer who postes the information online using the product in the same manner that the person who read the information intend to use it. So, the expectation is that higher levels of persona similarity and usage similarity will be associated with higher levels of message relevance, and will eventually lead to higher levels of eWOM impact (Kelley et al., 2016).

Bilgen and S. Zoghi (2016) in a recent research on consumers’ online buying intention have revealed that among many factors which affect online purchase intention, personal innovativeness, eWOM source credibility and customers’ perceived risk are the most important factors that affect online purchase intention. Authors have proposed that developing tools to make online purchase more secure and creating a positive eWom among customers can decrease customers’ perceived risk and increase online buying intention among Turkish customers (Bilgen and S. Zoghi, 2016).

Moreover, there are various e-WOM channels like forums, websites, social media etc. and adoption of customers can differ by these channels. Yan et al. (2016) have recently investigated the relations between e-WOM credibility and adoption on forums and social media and have proposed that there are some mediators in this relationship. According to the authors, source credibility affects e-WOM credibility positively (Yan et al., 2016: 71). Hence;

H3: e-Wom source credibility has a significant effect on perception of risk.

H4: e-Wom source credibility has a significant effect on online buying intention.

2.5. Perception of Risk in Online Buying Behavior

Perceived risk has been identified as a critical determinant of consumers' willingness to buy a new product or brand (Peter et al. 1975; Grewal and et al., 1994). There is an important difference between risk and perceived risk. Risk or objective risk is based on the outcomes of alternatives and their probabilities (Das and Teng, 2001). On the other hand, perceived risk or subjective risk refers to customer’s estimate of objective risk (Dowling 1986; Fischhoff 1985). So customers may have different estimates of risk in different situations.

In consumer behavior literature, risk perception has been defined as the expectation of losses associated with purchase of goods or services and it has a restrainer function in purchase behavior (Peter and Ryan, 1976). Customer perceived risk is related to the perception of uncertainty and adverse consequences of buying a product or service. Risk can be observed not only particular in pre-purchase process, but also on the time of purchasing and after the purchase process. In order to reduce risk, customers gather information from the firms’ communication channels. Lowering the risk leads to increasing in willingness to pay and perceived value for money. Even in post-purchase process, customers can face information from environment which increases their risk perception (Petersen and Kumar, 2015: 270).

Frequency of purchase, level of involvement in the purchase decision and satisfaction with previous purchase experience are among the most important factors that affect the

impact of perceived risk on online purchase behavior (Pires et al., 2004). Strength of the relationship between perceived risk and intentions can differ among frequently shopping customers and non-frequently shopping customers. One of the recent researches has proved that the levels are different across groups and experience plays a significant role (Martin, Mortimer and Andrews, 2015: 91). Keh and Sun (2008) have compared perceived risk among Chinese and Singaporean customers in 2008. They have gathered data from 309 Chinese and 193 Singaporean consumers. Research results have showed that customer perceived risk differ by cultures. Also, personal and non-personal risks had varying levels of impact on perceived value and customer satisfaction (Keh and Sun, 2008: 140). Pappas (2016) has analyzed the relation between different variables such as customer perceived risk, product marketing strategies, web-vendor marketing strategies, product consumer trust, web-vendor consumer trust and intention to buy online. Findings of the study have indicated that the customers' perception of risk can be about product quality, product price, web-vendor quality, web-vendor security (Pappas, 2016: 96). Hence;

H₄: Perception of risk has a significant effect on online buying intention.

3. Research Methodology

This study aim to expand the knowledge of consumers' buying behavior on online platforms by examining the impact of e-WOM Credibility, perceived behavioral control and risk perception on consumers' online buying intention in Germany. A descriptive research has been designed in order to define the relations between different variables. The target population of the research is young consumers, university students, who purchase products and services online. Convenience sampling method has been used to gather data from 123 respondents through online survey. Scales used in this research have been adopted from literature. All variables of the study have been measured by 5 item Likert scales.

4. Data Analysis and Findings

Demographics of respondents have been summarized on table 1. The frequency of gender is almost the same between male (49.6 percent) and female (50.4 percent) participants. The majority of participants are single (95.9 percent), mostly bachelor student (63.4 percent), from 19 to 30 years old (91.1 percent) and earning less than 999 Euros per month (64.2 percent). Young consumers have been selected because of their adoption to new technologies and devices such as smartphones and tablets and using internet and social media as the main source of information searching.

Table 1: Descriptive Analysis

		Frequency	%
Gender	Female	62	50.4
	Male	61	49.6
Marital Status	Single	118	95.9
	Married	5	4.1
Age	Less than 18	1	0.8
	19-30	112	91.1
	31-40	9	7.3
	41-50	1	0.8
Occupation	Bachelor Student	78	63.4
	Master Student	35	28.5
	PhD Student	1	0.8
	Post-doc Student	1	0.8
	Employee	6	4.9
	Self-employed	1	0.8
	Other	1	0.8
Income	Less than 999 Euro/Month	79	64.2
	From 1000 to 1999 Euro/Month	32	26.0
	From 2000 to 2999 Euro/Month	5	4.1
	Above 3000 Euro/Month	7	5.7

We have asked three questions about participants' online shopping experience including: have the respondents ever done online shopping before, how often they do online shopping and which items they normally prefer to purchase online. Table 2 shows the frequency of the answers. All respondents have experienced online shopping before. Most popular items are books, tickets and clothes. 62.6 percent of the respondents have mentioned that they are buying products and goods occasionally.

Table 2: Online Buying Frequencies

	Frequency	%
Several times per week	7	5.7
Once a week	17	13.8
Fortnightly	22	17.9
Occasionally	77	62.6

Confirmatory factor analyses (CFAs) have been used to define factor structures of scales used in the research. CFA of perceived behavioral control has been shown on the figure 1.

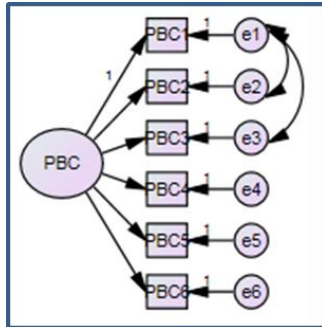

Chi square/Degree of Freedom: 1.761; RMSEA: 0.079; GFI: 0.968; CFI: 0.985

Figure 1: Perceived Behavioral Control Scale's CFA

e-WOM credibility has 4 dimensions including expert, trust, object and HMPH. The CFA model of e-WOM credibility fits as well (Figure 2).

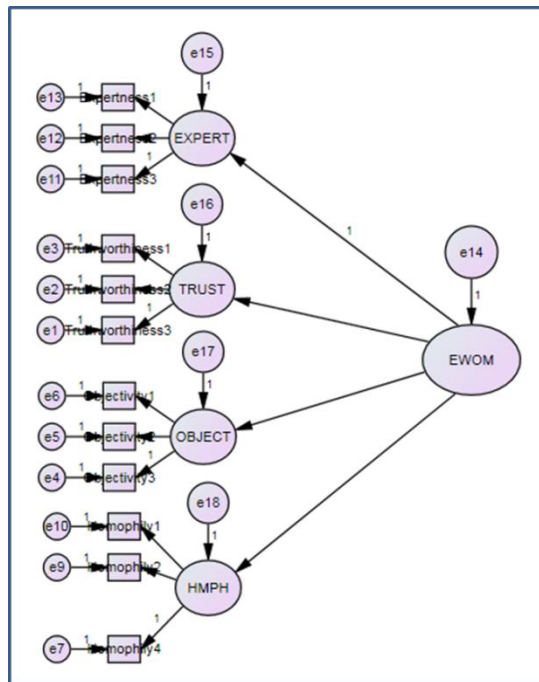

Chi square/Degree of Freedom: 1.458; RMSEA: 0.061; GFI: 0.911; CFI: 0.910

Figure 2: e-WOM Credibility Scale's CFA

Perception of Risk Scale has 5 items. Findings indicate that the model fits for Perception of Risk Scale (Figure 3)

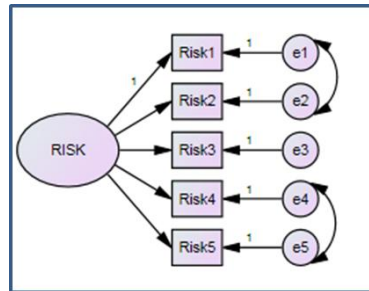

Chi square/Degree of Freedom: 0.426; RMSEA: 0.000; GFI: 0.996; CFI: 1.000

Figure 3: Perception of Risk Scale’s CFA

Online shopping intention has 3 items and its CFA has been presented on figure 4.

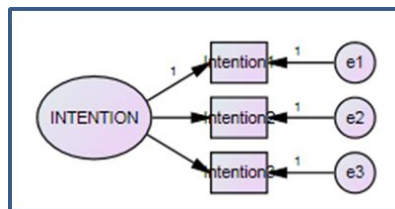

Chi square/Degree of Freedom: - ; RMSEA: 0.494; GFI: 1.000; CFI: 1.000

Figure 4: Online Shopping Intention Scale’s CFA

Moreover, reliability results of the scales have been summarized on Table 3. Cronbach’s Alpha of all scales indicate that all the scales used in this research are reliable.

Table 3: Reliability Results of the Scales

Scale	Cronbach’s Alpha
Perceived Behavioral Control	0.876
e-WOM Source Credibility	0.760
Perception of Risk	0.776
Online Buying Intention	0.747

Multiple regression analyses have been applied to test the research hypotheses. First hypothesis, “Perceived behavioral control has a significant effect on perception of risk”, has been supported. Table 4 shows the results.

Table 4: Multiple Regression between Perceived Behavioral Control and Perception of Risk

R	R ²	F	Beta	t	p
0.248	0.061	7.927	-0.248	-2.816	0.006

As seen in table 5, the second hypothesis of the study, “Perceived behavioral control has a significant effect on online buying intention” has been supported too; however the strength is very low.

Table 5: Multiple Regression between Perceived Behavioral Control and Online Buying Intention

R	R²	F	Beta	t	p
0.095	0.009	1.113	0.294	1.055	0.294

The third hypothesis of the study, “e-Wom source credibility has a significant effect on risk perception”, has been rejected. Table 6 shows the results.

Table 6: Multiple Regression between e-Wom source credibility and Perception of Risk

R	R²	F	p		Beta	t	p	VIF
0.132	0.018	0.527	0.716	Expertness	-0.063	-0.537	0.592	1.665
				Trustworthiness	0.020	0.184	0.854	1.368
				Objectivity	-0.086	-0.807	0.421	1.356
				Homophily	0.135	1.287	0.201	1.324

The fourth hypothesis of the study, “e-Wom source credibility has a significant effect on online buying intention” has been rejected. The results can be seen in table 7.

Table 7: Multiple Regression between e-Wom Source Credibility and Online Buying Intention

R	R²	F	p		Beta	t	p	VIF
0.177	0.031	0.951	0.437	Expertness	-0.073	-0.623	0.535	1.665
				Trustworthiness	0.098	0.925	0.357	1.368
				Objectivity	0.006	0.055	0.956	1.356
				Homophily	0.170	1.634	0.105	1.324

The fifth hypothesis of the study, “Perception of risk has a significant effect on online buying intention”, has been rejected. Table 8 shows the results.

Table 8: Multiple Regression between Perception of Risk and Online Buying Intention

R	R²	F	Beta	t	p
0.036	0.001	0.159	-0.036	-0.399	0.690

5. Discussion and Conclusion

In this research we have examined the impact of risk perception on German consumers’ online buying intention. Findings indicate that perceived behavioral control has a negative effect on customers’ perception of risk and a positive effect on online buying intention. In consumer behavior literature e-Wom has been acknowledged as a crucial factor for reducing risk perception in online purchase process (Lutz and Reilly, 1974). Risk perception itself has been identified as a key factor in buying decision-making process and has a restrainer function in purchase behavior (Peter and Ryan, 1976). In current research, however, e-Wom credibility does not have any significant effect on customers’ perception of risk and online buying intention. Moreover, risk perception does not have any significant effect on online buying intention.

A strict interpretation of results emphasizes the need of focusing on cultural aspects of German consumers. Risk perception is consumers’ subjective evaluation of probability of various outcomes, so personal characteristic, culture and environment may affect

customers' decision making process significantly and exhibit different risk behaviors in online shopping process (S. Zoghi and Arslan, 2017). We have used Hofstede's cultural dimensions including Individualism, Indulgence and Uncertainty Avoidance , to interpret the results.

Individualism has been defined as "the degree of interdependence a society maintains among its members" and Indulgence has been defined as "the extent to which people try to control their desires and impulses". Germany is an individualist (the score is 67) and a highly decentralized society, loyalty is based on personal preferences. The low score of 40 on indulgence dimension indicates that German consumers have a tendency to control the pleasure of their desires (hofstede-insights.com- last visited on 30.07.2018). So, the probability of hedonic shopping is very low in online and offline consumer markets in Germany. In a cross-cultural study on online shopping behavior, Smith and et al (2013) have compared consumers in Norway, Germany and United State to examine the differences in their shopping behavior. Findings of the research show that full Technology Acceptance Model (TAM) does not hold for the European samples and there is no meaningful relationship between affective involvement and behavioral intention in German sample.

Uncertainty avoidance has been defined as "The extent to which the members of a culture feel threatened by ambiguous or unknown situations and have created beliefs and institutions that try to avoid these". The score of Uncertainty avoidance in Germany is 65. German consumers follow a systematic approach toward shopping process. There is a strong preference for deductive approach in thinking and planning in Germany. They make their online purchase decision based on reliable sources of information and they compare the selected product or service to similar products or services in the market. German consumers compensate for their uncertainty by strongly relying on expertise (hofstede-insights.com- last visited on 30.07.2018). Quick-and-easy transactions and benefitting from expert advice are among the most important motivations to do online shopping in German consumers. Marketing promotions such as lower prices, discounts and fad in common consumer items, however, are not affecting German consumers significantly (Join the Dots, 2016).

Moreover, Germany is one of the most cash-intensive economies among developed countries. German consumers for different reasons such as privacy issues prefer to use cash, Direct Debits or to be invoiced on delivery. Contactless payments and mobile payments via smartphones have been unsuccessful due to the trust concerns in German consumers (Euromonitor International, 2015).

Altogether, Germans are very concerned about their personal data protection and due to a systematic decision making process they try to minimize the risk perception in online shopping platforms. On the other hand, due to their individualist personal characteristics they are not getting influenced by environmental factors such as e-Wom unless they find the source of information credible and reliable.

References

- Ajzen, I. (1991). The theory of planned behavior. *Organizational Behavior and Human Decision Processes*, 50, 179–211.
- Ajzen, I. & Fishbein, M. 1977, “Attitude-behavior relations: A theoretical analysis and review of empirical research”, *Psychological Bulletin*, Vol. 84 No. 5, pp. 888-918.
- Ajzen, I., & Fishbein, M. (2005). The influence of attitudes on behavior. In D. Albarracín, B. T. Johnson, & M. P. Zanna (Eds.), *The handbook of attitudes* (pp. 173-221). Mahwah, NJ: Erlbaum.
- Ajzen, I., Brown, T. C., & Carvajal, F. (2004). Explaining the discrepancy between intentions and actions: The case of hypothetical bias in contingent valuation. *Personality and Social Psychology Bulletin*, 30, 1108–1121.
- Agarwal, R. & Prasad, J. (1998). A Conceptual and Operational Definition of Personal Innovativeness in the Domain of Information Technology, *Information Systems Research*, 9 (2), pp. 204-215.
- Bandura, A. (1982). Self-efficacy mechanism in human agency. *American Psychologist*, 37, 1226-1247.
- Bilgen I. and Soleimani Zoghi F., “A research on the impact of EWOM source credibility and personal innovativeness on online shopping intention in Turkish customers,” *Journal of Management, Marketing and Logistics*, Vol.4, pp. 143-151, 2017.
- Campbell, D. T. (1963). Social attitudes and other acquired behavioral dispositions. In S. Koch (Ed.), *Psychology: A study of a science* (Vol. 6, pp. 94–172). New York: McGraw-Hill.
- Das, T. K., & Teng, B. 2001a, “Trust, control, and risk in strategic alliances: An integrated framework”, *Organization Studies*, 22, 251-283.
- Davis, F. D. 1989, “Perceived Usefulness, Perceived Ease of Use, And User Acceptance of information technology”, *MIS Quarterly*, 13, 3; ABI/INFORM Global, pg. 319.
- Dowling, G. R. 1986, “Perceived Risk: The concept and its measurement”, *Psychology and Marketing*, 3: 193-210.
- Dutta, D. K., Gwebu, K.L. & Wang, J. (2015). Personal innovativeness in technology, related knowledge and experience, and entrepreneurial intentions in emerging technology industries: a process of causation or effectuation?, *International Entrepreneurship and Management Journal*, 11, pp. 529-555, DOI 10.1007/s11365-013-0287-y .
- Elliot, Steve and Sue Fowell (2000), “Expectations versus Reality: A Snapshot of Customer Experience on Internet Retailing,” *International Journal of Information Management*, 20 (5), 323–37.
- Fishbein, M., & Ajzen, I. (1975). *Belief, attitude, intention, and behavior: An introduction to theory and research*. Reading, MA: Addison-Wesley.
- Fischhoff, B. 1985, “Managing Risk Perceptions”. *Issues in Science and Technology*, 2/1: 83-96.

- Gentile, Chiara, Nicola Spiller and Giuliano Noci (2007), "How to Sustain the Customer Experience: An Overview of Experience Components that Cocreate Value with the Customer," *European Management Journal*, 25 (5), 395–410.
- Grewal, Dhruv, Jerry Gotlieb, and Howard Marmorstein (1994), "The Moderating Effects of Message Framing and Source Credibility on the Price-Perceived Risk Relationship," *Journal of Consumer Research*, 21 (1), 145–53.
- Hennig-Thurau, T. , Gwinner K. P., Walsh G. & Gremler D. D. 2004, "Electronic Word-of-Mouth via Consumer-Opinion Platforms: What Motivates Consumers to Articulate Themselves on the Internet?" *Journal of Interactive Marketing*, 18 (1), 38-52.
- Jackson, J.D., Yi, M.Y. & Park, J.S. (2013). An empirical test of three mediation models for the relationship between personal innovativeness and user acceptance of technology, *Information & Management* 50, pp. 154-161.
- Keh, H. T. & Sun, J. (2008). The Complexities of Perceived Risk in Cross-Cultural Services Marketing, *Journal of International Marketing*, 16 (1), pp. 120-146.
- Kelley O'Reilly, Amy MacMillan, Alhassan G. Mumuni & Karen M. Lancendorfer (2016) Extending Our Understanding of eWOM Impact: The Role of Source Credibility and Message Relevance, *Journal of Internet Commerce*, 15:2, 77-96.
- Lee, K-T. & Koo, D-M. (2012). Effects of attribute and valence of e-WOM on message adoption: Moderating roles of subjective knowledge and regulatory focus, *Computers in Human Behavior*, 28, PP. 1974-1984.
- Levy, S. & Gvili, Y. (2015). How Credible is E-Word of Mouth Across Digital-Marketing Channels? The Roles of Social Capital, Information Richness, and Interactivity, *Journal of Advertising Research*, March, pp. 95-109, DOI: 10.2501/JAR-55-1-095-109.
- Lin, Z. & Filieri, R. (2015). Airline passengers' continuance intention towards online check-in services: The role of personal innovativeness and subjective knowledge, *Transportation Research Part E* 81, pp. 158-168.
- Lopez-Nicolas, C. & Molina-Castillo, F.J. (2008). Customer Knowledge Management and E-commerce: The role of customer perceived risk, *International Journal of Information Management*, 28, pp. 102-113.
- Lutz, R. J., & Reilly, P. J. 1974, "An exploration of the effects of perceived social and performance risk on consumer information acquisition", *Advances in Consumer Research*, 1, 393- 405.
- Martin, J., Mortimer, G. & Andrews, L. (2015). Re-examining online customer experience to include purchase frequency and perceived risk, *Journal of Retailing and Consumer Services*, 25, pp. 81-95.
- Motwani, B. (2016). Prediction of Buying Intention for Online Shopping: An Empirical Study, *The IUP Journal of Marketing Management*, 15 (4), pp. 7-30.
- Obiedat, R. (2013). Impact of Online Consumer Reviews on Buying Intention of Consumers in UK: Need for Cognition as Mediating Role, *International Journal of Advanced Corporate Learning*, 6 (2), pp. 16-21, <http://dx.doi.org/10.3991/ijac.v6i2.2910>.

- Pappas, N. (2016). Marketing strategies, perceived risks, and consumer trust in online buying behavior, *Journal of Retailing and Consumer Services*, 29, pp. 92-103.
- Peter, J. Paul and Lawrence X. Tarpey Sr. (1975), "A Comparative Analysis of Three Consumer Decision Strategies," *Journal of Consumer Research*, 2 (1), 29–37.
- Peter, J.P. and Ryan, M.J. (1976), "An investigation of perceived risk at the brand level", *Journal of Marketing Research*, Vol. 2 No. 13, pp. 184- 188.
- Petersen, J.A. & Kumar, V. (2015). Perceived Risk, Product Returns, and Optimal Resource Allocation: Evidence from a Field Experiment, *Journal of Marketing Research*, Vol. LII, pp. 268-285.
- Pires, G., Stanton, J. & Eckford, A., (2004). "Influences on the Perceived Risk of Purchasing Online", *Journal of Consumer Behavior*, Vol. 4, No. 2: 118-131.
- Rose, S., Clark, M., Samouel, P. and Hair, N. (2012). Online customer experience in e-retailing: An empirical model of antecedents and outcomes. *Journal of Retailing*, 12 (1): 23-56.
- Rogers E.M.(2003). "Diffusion of Innovations", 5th ed., The Free Press, New York, 2003.
- M.Y. Yi, J.D. Jackson, J.S. Park, J. Probst, Understanding information technology acceptance by individual professionals: toward an integrative view, *Information and Management* 43, 2006, pp. 350–363.
- Smith, R., Deitz, G., Royne, M. B., Hansen J. D., Grünhagen, M., Witte, C. (2013). Cross-cultural examination of online shopping behavior: A comparison of Norway, Germany, and the United States, *Journal of Business Research*, Vol. 66, Iss. 3, pp 328-335.
- Soleimani Zoghi, F. & Arslan, F. M. (2017). The Effect of Relational Risk Perception on Supplier's Performance; An Empirical Study on Turkish Strategic Alliances, *Review of Socio-Economic Perspectives*, Vol. 2(2), pp. 67-84. DOI: 10.19275/RSEP018.
- Yan, M. O. & Li-Ming, A.K. (2015). Leisure Tourists' Online Buying Intentions in Malaysia, *The Journal of Developing Areas*, 49 (5), pp. 325-333.
- Yan, Q., Wu, S., Wang, L., Wu, P., Chen, H. & Wei, G. (2016). E-WOM from e-commerce websites and social media: Which will consumers adopt?, *Electronic Commerce Research and Applications*, 17, pp. 62-73.

<http://www.mintel.com/press-centre/retail-press-centre/93-of-german-consumers-today-shop-online> Last visited on 16.07.2018
<https://spark.adobe.com/page/zPwDF/> Last visited on 16.07.2018
Consumer Lifestyles in Germany, Euromonitor International, October 2015
<https://www.hofstede-insights.com/country-comparison/germany/> last visited on 30-07-2018